

INTERPLANT STANDARD – STEEL INDUSTRY		
	<b>SPECIFICATION FOR CRANE WHEELS</b>	<b>IPSS:1-08-001-18</b> <i>(Third Revision)</i>
	Based on IS 4137:1985	Formerly: IPSS:1-08-001-09 (Second Revision)

## 0. FOREWORD

- 0.1** Interplant Standardization activity in Steel Industry is being pursued by IPSS Secretariat which functions under Centre for Engineering & Technology (CET), the in-house consultancy organization of SAIL.
- 0.2** This Interplant Standard has been prepared by the Standards Committee on Lifting and hoisting Equipment, IPSS 1:8 with the active participation of the representatives of all the steel plants, established crane manufacturers and leading consultants and was adopted with second revision in March, 2009. The Standard discussed again in presence of experts from SAIL, RINL, TATA STEEL, ESSAR, JSPL and Consultants of MECON, HEC & DASTURCO and revised with third revision in **August, 2018**.
- 0.3** Interplant Standards for steel industry primarily aim at achieving rationalization and unification of parts and assemblies used in steel plant equipment and provide guidance in indenting stores or equipment by individual steel plants. For exercising effective control on inventories, it is advisable to select a fewer number of sizes/types from those mentioned in this standard. These limited sizes/types can be adopted as Plant Standards for an individual steel plant. It is not desirable to make deviations in technical requirements.
- 0.4** This standard was first published in April 1975. In the first revision of this standard done in 1983, Second revision done in March 2009 with a provision for lifting of wheel by introducing holes in the web of the wheel was incorporated and a new figure for tyred wheel was added. Wheel of 630 mm size was introduced instead of the wheel of 600 mm size prescribed earlier. The formula for calculating the wheel diameter was also deleted in the first revision.
- 0.5** This revision incorporates the changes based on the experience of the user plants as well as revisions of Indian Standards referred to in this standard.
- 1. SCOPE** – This Interplant Standard covers the requirements of crane wheels for steel industry and is generally based on IS 4137:1985 `Code of practice

for heavy duty electric overhead travelling cranes including special service machines for use in steel works (first revision)'.

2. **MOUNTING** – Crane wheel shall be suitable for adoption on live axles mounted on antifriction bearings fitted with 'L' brackets. The wheels shall normally have cylindrical tread with flanges, wherever necessary, to guide the crane effectively and to prevent derailment. The wheels shall be mounted in such a manner as to facilitate easy removal and replacement. For under-slung cranes, wheels of taper tread with single flange may be used.

### 3. MATERIAL AND HEAT TREATMENT

- 3.1 The crane wheels shall be of forged steel only. However, this does not prevent the use of steel tyred wheels having steel centers for existing cranes.
- 3.2 The material used for forged wheel shall conform to Steel 55C8/ 65C6 of IS 2004:1991 'Carbon steel forgings for general engineering purposes (third revision)' or C55 Mn75 of IS 1570 (Pt 1& 2) or 42 Cr Mo4 of DIN EN 10083-3/ DIN 17200 and shall be sorbitized to minimum depth of 10 mm.
- 3.3 Alternatively, the material shall conform to ASP Gr.Ni-Cr Mo Steel / EN or 40 Ni 6 Cr 4 Mo 3 / 40 Ni 10 Cr 3 Mo 6 of IS 4367:1991 'Alloy steel forgings for general industrial use (first revision)' and shall be volume hardened to 320-350 BHN.

### 4. MAIN DIMENSIONS

- 4.1 The main dimensions of the wheel shall be as specified in Table 1.
- 4.2 Tolerance on the tread diameter shall be as given in Table 1. The boss, web, bore, tread, flange, wheel centre and rim etc may be suitably machined for the desired profile.

### 5. TESTING

- 5.1 The Wheel shall be 100% ultrasonically tested for level II and test report shall be submitted.

CRANE WHEEL

I.P.S.S.  
1-08-001

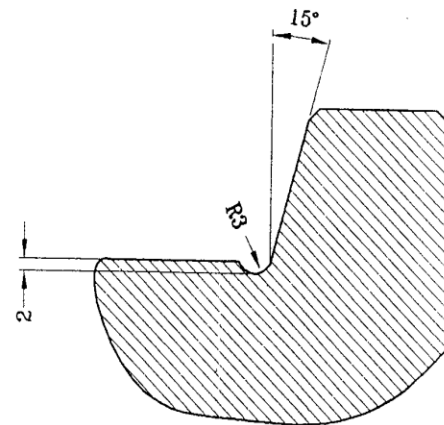
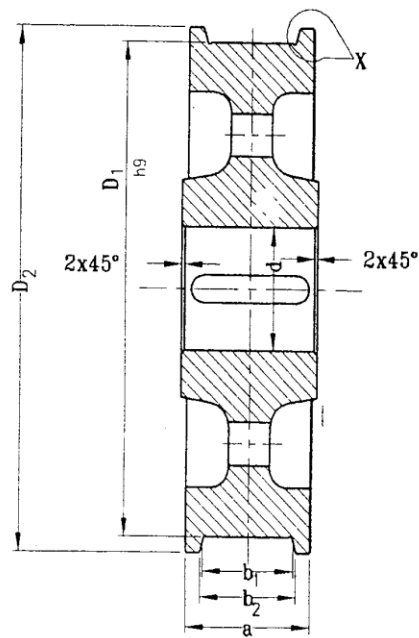

DETAIL - X  
SCALE = 1:1

SOLID WHEEL

FIG. 1

EXAMPLE FOR ORDER  
SOLIDWHEEL D =  $\varnothing 800B$

**DIMENSIONS OF CRANE WHEEL,(SOLID)**  
**( Clause 4.1 & 4.2)**

( ALL DIMENSIONS IN MILLIMETRE )

Sl. No.	Wheel Size	Dia. $D_{1H9}$	b <sub>1</sub>	b <sub>2</sub>	a	d <sub>H7</sub>	B <sub>2</sub>	Recommended Rail
1	2	3	4	5	7	8	9	10
i)	200	200	60	68	100	50	230	14.87 Kg./m. (30 lb./yd.) rail, 40x40mm. billet
ii)	250	250	60	68	100	65	280	14.87 Kg./m. (30 lb./yd.) rail, 40x40mm. billet
iii)	320	320	70	81	110	80	360	29.74 Kg./m. (60 lb./yd.) rail, CR : 50, CR : 60
iv)	400	400	80	94	125	95*	450	29.74 Kg./m. (60 lb./yd.) rail, CR : 50, CR : 60
v)	500	500	110	124	160	115*	550	CR : 80
vi)	630A	630	110	124	160	135*	680	CR : 80
	630B	630	130	144	180	135*	680	CR : 100
vii)	710A	710	130	144	180	135*	760	CR : 80
	710B	710	150	164	210	155*	760	CR : 120
	710C	710	110	124	160	135*	760	CR : 100
viii)	800A	800	120	134	180	155*	850	CR : 80
	800B	800	150	164	210	155*	850	CR : 100 / CR : 120
	800C	800	180	194	240	220*	850	CR : 140
ix)	900A	900	120	134	180	160*	950	CR : 80
	900B	900	150	164	210	175*	950	CR : 100 / CR : 120
	900C	900	180	194	240	220	950	CR : 140
x)	1000A	1000	150	164	210	220	1050	CR : 120
	1000B	1000	180	194	240	220	1050	CR : 140

Note-1:- The boss diameter of the crane wheels shall be so designed as to accommodate increased bore up to 20 mm more than that specified against each type, marked asterisk (\*)

Note-:2 Minimum diameter of cross travel and long travel wheels shall be 200 mm and 400 mm respectively for EOT cranes.

Note -:3 Wheels of tread dia 320 mm (minimum) may be used for long Travel motion of Single Girder EOT Crane.