

| INTERPLANT STANDARD – STEEL INDUSTRY | | |
|--|--------------------------------|--|
| IP SS  | SPECIFICATION FOR THIMBLES | IPSS:1-08-013-18 (Second Revision) |
| | Based on IS 2315:1978 (R 2017) | Formerly-: IPSS:1-08-013-99 (First Revision) |

0. FOREWORD

- 0.1 This Inter Plant Standard has been prepared by the Standards Committee on Lifting and Hoisting Equipment, IPSS 1.8 with the active participation of the representatives of all the steel plants, established manufacturers and leading consultants and was adopted with first revision in April 1999. The Standard discussed again in presence of experts from SAIL, RINL, TATA STEEL, ESSAR, JSPL and Consultants of MECON, HEC & DASTURCO and revised with second revision in **August, 2018**.
- 0.2 Inter Plant Standards for steel industry primarily aim at achieving rationalization and unification of parts and assemblies used in steel plant equipment and provide guidance in indenting stores or equipment by individual steel plants. For exercising effective control on inventories, it is advisable to select a fewer number of sizes types from those mentioned in this standard. These limited sizes/ types can be adopted as Plant Standards for an individual steel plant. It is not desirable to make deviations in technical requirements.
- 0.3 This standard was first published in 1989 and was first revised in April 1999. Although the technical contents of this standard are still valid, various Indian Standards mentioned, have been revised over a period of time. The necessary changes have been incorporated in this revision.

1. SCOPE

- 1.1 This Inter Plant Standard lays down the requirements for solid type thimbles for wire ropes.

2. DIMENSIONS

- 2.1 The dimensions of the thimbles shall be as given in Table-1.

3. TOLERANCES

- 3.1 Tolerances on untoleranced dimensions shall be +5%.

- 3.2 The dimensions- indicated as minimum shall be subject only to a tolerance of $\pm 5\%$ (dimensions C and F).
- 3.3 The pin-holes in solid thimbles -shall be drilled from the solid or bored to finished sizes to suit machined pins of the sizes specified (dimension M).

TABLE – 1**DIMENSIONS OF SOLID THIMBLES (Clauses 2.1 & 5.1.1)**

All dimensions in millimeters

| Nominal size of Rope | B | C | E | F Min | G | r1 | L | M Max |
|-----------------------------|----------|----------|----------|--------------|----------|-----------|----------|--------------|
| 1 | 2 | 3 | 4 | 5 | 6 | 7 | 8 | 9 |
| 8 | 33 | 11 | 46 | 9 | 4 | 4.4 | 25 | 12 |
| 10 | 44 | 15 | 58 | 11 | 6 | 5.5 | 32 | 16 |
| 12 | 60 | 20 | 82 | 13 | 8 | 6.6 | 44 | 22 |
| 14 | 60 | 21 | 82 | 15 | 8 | 7.7 | 44 | 22 |
| 16 | 70 | 23 | 94 | 17 | 10 | 8.8 | 50 | 25 |
| 18 | 80 | 26 | 104 | 19 | 12 | 9.9 | 56 | 28 |
| 20 | 88 | 28 | 116 | 21 | 12 | 11.0 | 64 | 32 |
| 22 | 100 | 30 | 125 | 24 | 14 | 12.1 | 72 | 34 |
| 24 | 104 | 33 | 140 | 26 | 14 | 13.2 | 76 | 38 |
| 26 | 114 | 36 | 150 | 27 | 16 | 13.75 | 82 | 42 |
| 28 | 124 | 39 | 165 | 31 | 18 | 15.95 | 88 | 44 |
| 32 | 140 | 45 | 190 | 34 | 20 | 19.2 | 100 | 50 |
| 36 | 154 | 50 | 208 | 38 | 20 | 21.0 | 114 | 56 |
| 38 | 169 | 56 | 234 | 41 | 22 | 22.8 | 125 | 64 |
| 40 | 169 | 56 | 234 | 44 | 22 | 24.6 | 125 | 64 |
| 44 | 190 | 65 | 260 | 47 | 25 | 26.4 | 140 | 68 |
| 48 | 206 | 67 | 275 | 51 | 28 | 28.8 | 150 | 75 |
| 52 | 229 | 72 | 300 | 55 | 32 | 30.6 | 165 | 78 |

NOTE: For wire ropes of intermediate sizes, the next larger size of thimbles shall be used.

* Dimension M is the standard pin-hole and the largest pin-hole for each thimble. Should a smaller pin-hole be required, the diameter of this shall be stated in the enquiry and order.

3.3.1 The tolerance on the pin-holes shall be as follows:

| Nominal size (diameter of Rope) mm | Tolerance mm |
|---------------------------------------|-----------------|
|---------------------------------------|-----------------|

| | |
|--------------------------------|--------|
| 8 up to and including 16 | + 0.13 |
| Over 16 up to and including 32 | + 0.25 |
| Over 32 | + 0.38 |

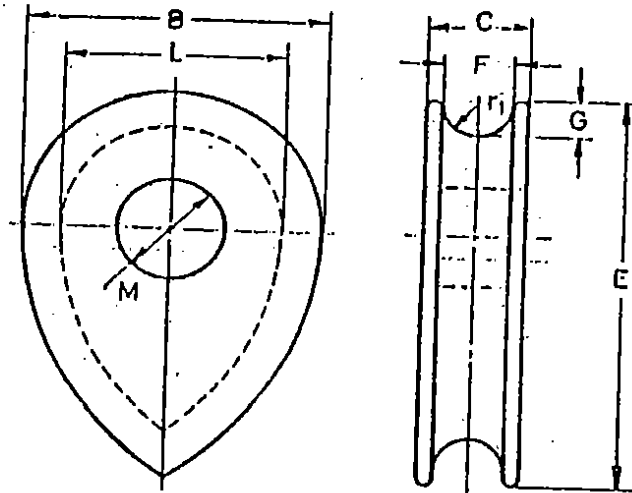

Figure - 1

4. MATERIALS

- 4.1 For Ropes upto and including 38 mm – Steel casting to Grade 280-520W of IS 1030:1998 'Specification for carbon steel castings for general engineering purposes (fifth revision)' or malleable iron castings to IS 14329:1995 'Malleable Iron Castings' or steel forging to designation 20C8 of IS 1875:1992 'Carbon steel billets, blooms, slabs and bars for forging (first revision)' (amendment 2)
- 4.2 For Ropes Over 38 mm – Steel Castings to Grade 280-520W of IS 1030:1998 or steel forging to designation 20C8 of IS 1875:1992.

5. GENERAL REQUIREMENTS

- 5.1 Boss and Lightening Hole in Solid Thimbles.
- 5.1.1 Solid thimbles may be provided with a projecting circular boss on each face, and if so provided, the faces of such bosses shall be machined and the thimbles shall conform in all other respects to the dimensions specified in Table-1.
- 5.1.2 Solid thimbles for ropes over 38 mm diameter may be made with a lightening hole or recess towards the point of the thimble of such size and or design that the strength of the thimble is not impaired.
- 5.2 Condition & Galvanizing
- 5.2.1 Solid Thimbles – Unless otherwise specified by the purchaser, solid

thimbles shall not be galvanized.

- 5.3 Workmanship – The thimbles shall be free from roughness and sharp edges liable to injure the wire tope.
- 5.4 Freedom from Defects – Each thimble shall be carefully examined and shall be deemed to comply with standard only if found free from flaw or defect.

6. **DESIGNATION**

- 6.1 The designation of the thimbles shall include the following
- a) Method of manufacture- Forged (F) or Cast (C)
 - b) Anti-corrosive coating – Gavanized (G) or Not Galvanized (NG)
 - c) Diameter in mm of the wire rope for which it is suitable, and
 - d) Number of this standard.

Example :

A thimble, which is forged, ungalvanized, suitable for a wire rope of 20 mm diameter shall be designated as:

Thimble FNG 20 – IPSS: 1-08-013-18

7. **MARKING**

- 7.1 The thimbles shall be legibly marked with the nominal size at a convenient place on the front size.
-